

TED (15) 3024  
(Revision-2015)

**A20-00255**

Reg.No.....  
Signature.....

DIPLOMA EXAMINATION IN ENGINEERING/TECHNOLOGY/  
MANAGEMENT/COMMERCIAL PRACTICE, APRIL-2020

**MACHINE DRAWING**

[Maximum marks: 75]

(Time: 2.15 Hours)

- [Note:- 1. All dimensions are in mm  
2. First angle projections is to be followed.  
3. Missing data if any may be suitably assumed.  
4. Both sides of the drawing sheet may be used.  
5. Sketches accompanied.]

**PART-A**

(Answer any *One* out of two questions. Each question carries 20 marks)

**UNIT -I**

- I. Draw the profile of the following thread forms of pitch 25mm.  
(a). British Standard Withworth (BSW) thread. (b). ISO Metric thread. (20)

**OR**

- II. Draw two views of a single riveted double strap butt joint. Take thickness of plates as 10mm. Dimension the drawing in terms of the diameter of the rivet. (20)

**PART-B**

(Answer any *One* out of four questions. Each question carries 40 marks)

**UNIT-II**

- III. An isometric view of a knuckle joint is shown in Fig.I .Drawing the following views:  
(a). Elevation, top half in section. (b). End view, looking from left side. (40)

**OR**

- IV. An isometric view of a flanged coupling unprotected type is shown in Fig.II. Draw the top half sectional elevation and end view looking from the bolt head side. Show all relevant dimensions. (40)

### UNIT-III

V. Detailed views of a Plummer block are shown in Fig. III. Assemble the parts and draw right half sectional front view and top view. Prepare the bill of material. (40)

OR

VI. Detailed views of a Stuffing box are shown in Fig. IV. Assemble the parts and draw a left half sectional elevation and a plan of the stuffing box. Prepare the bill of material. (40)

### PART-C

(Answer *One* out of two questions. Each question carries 15 marks)

### UNIT-IV

VII. Draw the symbols of the following welded joints.

- (a). Square butt weld.
- (b). Single –V butt weld.
- (c). Single- bevel butt weld.
- (d). Single – U butt weld.
- (e). Fillet weld.

(15)

OR

VIII. Double line orthographic layout of a piping or system is shown in Figure V. Draw the corresponding single line orthographic layout. (15)

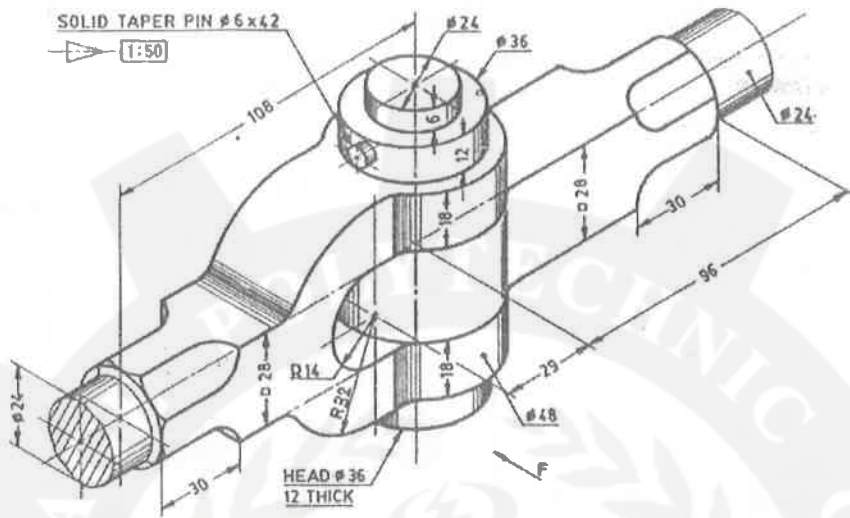

Fig.I - Knuckle Joint

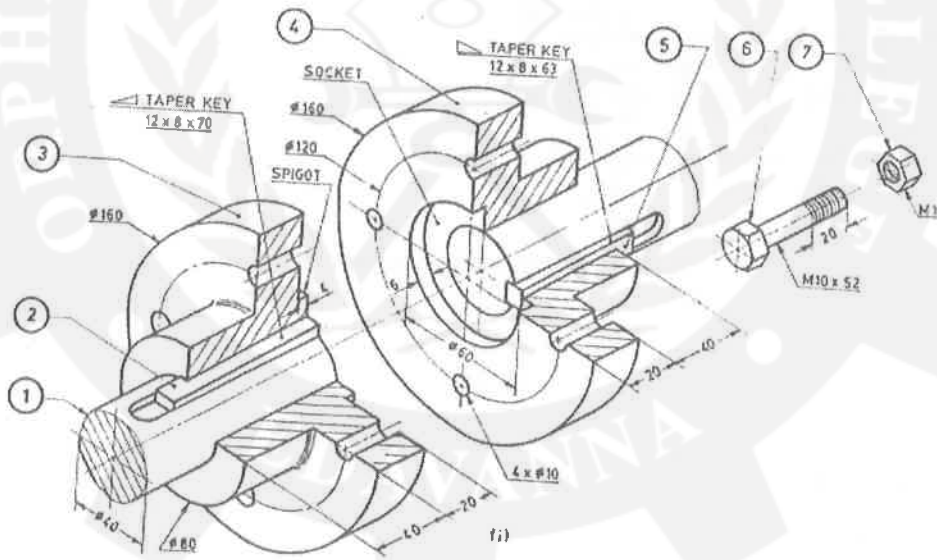

Fig.II - Flanged coupling unprotected type

1	Shaft end
2	Key (Long)
3	Flange (Male)
4	Flange (Female)
5	Key (Short)
6	Bolt
7	Nut

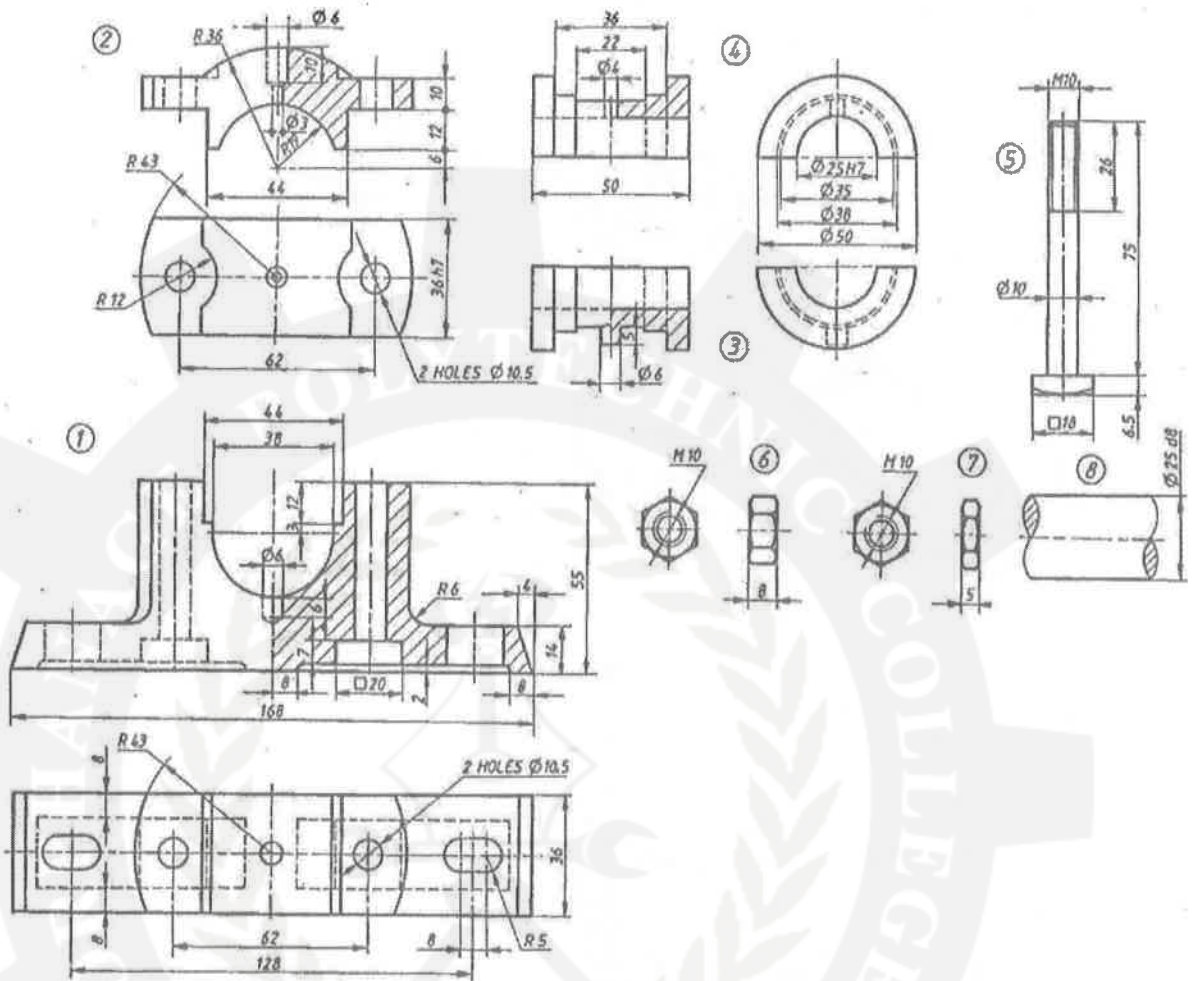

Fig.III – Details of Plummer block

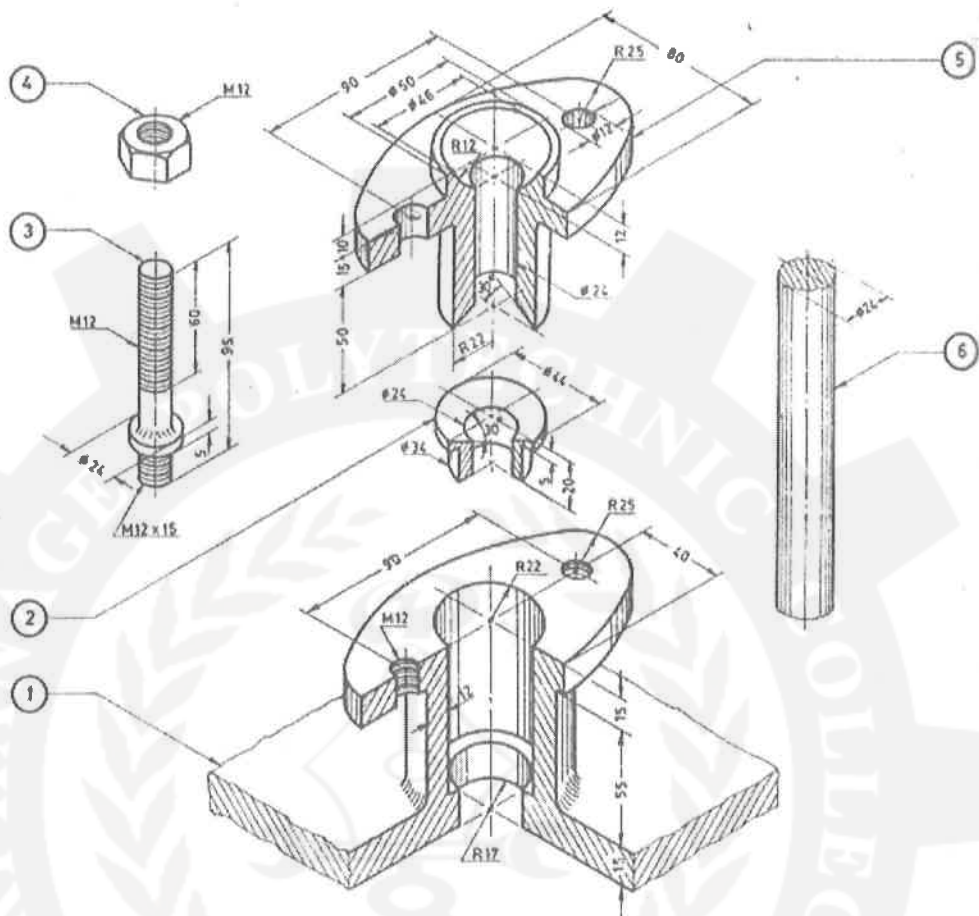

Fig.IV – Details of stuffing box

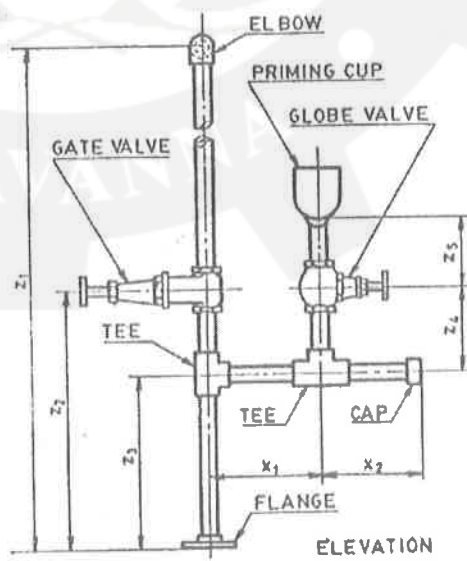

Fig.V- Double line orthographic layout